

# 1. About Myself

## ANSWERS

### WARM UP

Ans. Do it yourself.

### TEST YOURSELF

#### A. Tick (✓) the things you can do.

1. I can tie my shoe laces.
2. I can count up to 100.
3. I can ride a bicycle.
4. I can comb my hair.
5. I can pack my school bag.

<input type="checkbox"/>
<input type="checkbox"/>
<input type="checkbox"/>
<input type="checkbox"/>
<input type="checkbox"/>



Ans. Do it yourself.

#### B. Given below are some activities. Colour the circles blue against the activities you like to do.

1. Read a book
2. Ride a bicycle
3. Listen to music
4. Make a drawing
5. Talk to friends

<input type="checkbox"/>
<input type="checkbox"/>
<input type="checkbox"/>
<input type="checkbox"/>
<input type="checkbox"/>



Ans. Do it yourself.

### CREATIVE CORNER

#### ACTIVITY

Dip your thumb in water colour and make a thumbprint.

Ans. Do it yourself.

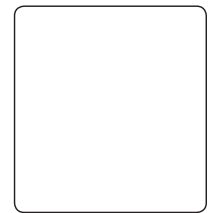

#### LIFE SKILLS

Always respect your parents and elders.

The teacher should tell and explain life skills and tell how they should be inculcated in students.

# 2. Our Body

## ANSWERS

### WARM UP

We have five fingers in each hand. Write their names. Use words from the box.

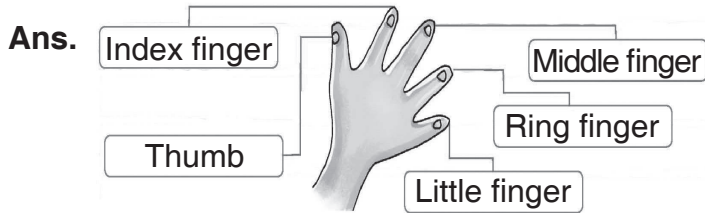

### TEST YOURSELF

#### A. Tick (✓) the correct answers.

1. Which of these organs is an internal organ?

- (a) nose
- (b) heart

2. We hold things with

- (a) legs
- (b) hands

3. We smell with our

- (a) nose
- (b) ears

4. We feel with our

- (a) ears
- (b) skin

#### B. Answer these questions.

1. Name any two internal organs.

Ans. Heart and lungs.

2. Name two external organs.

Ans. Nose and head.

3. How many sense organs do we have?

Ans. We have five sense organs.

### CREATIVE CORNER

#### ACTIVITIES

Unjumble the names of body parts. Write the correct name in the given space.

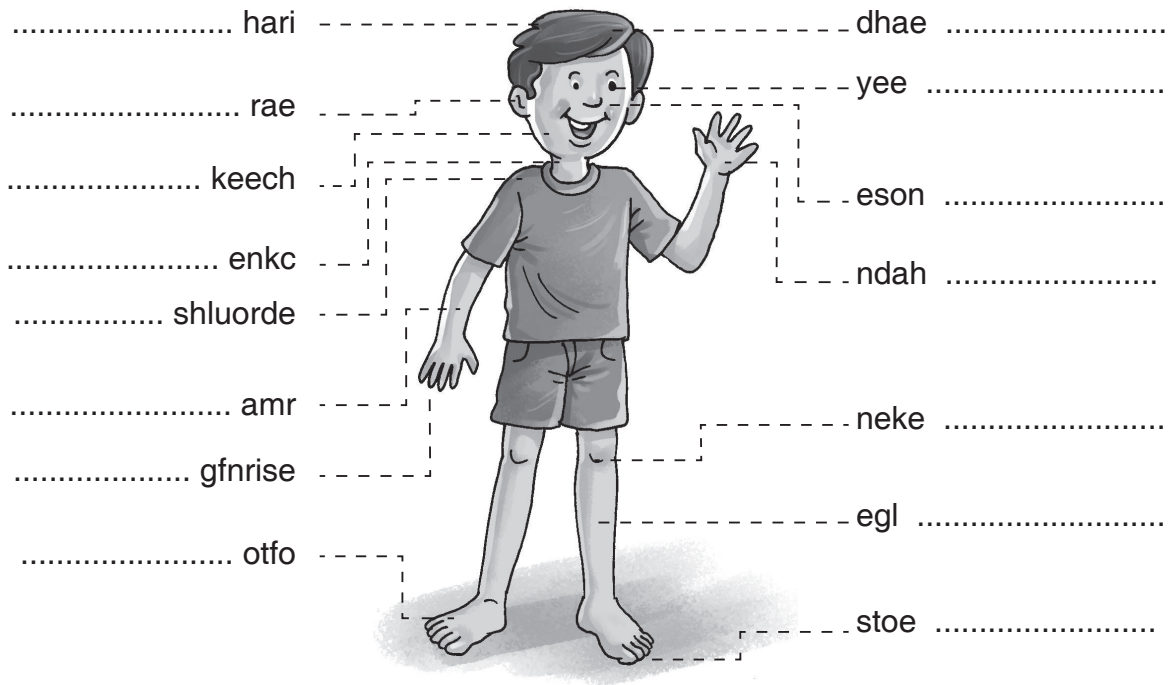

## LIFE SKILLS

Tick (✓) the correct posture.

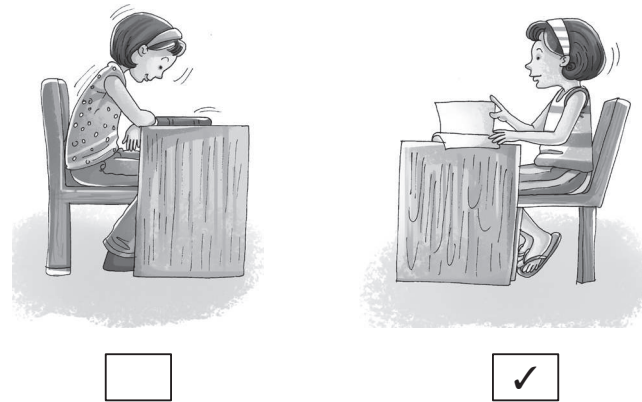

The teacher should tell and explain life skills and tell how they should be inculcated in students.

**A. Hello! My name is Mini.**

I am seven years old.

I am a girl.

What is your name?

My name is \_\_\_\_\_.

I am \_\_\_\_\_ years old.

**Ans.** Do it yourself.

**B. Write 'E' below the external organ and 'I' below the internal organ.**

E



E

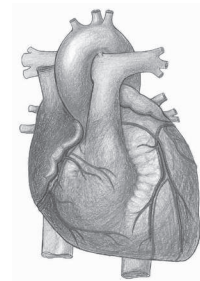

I

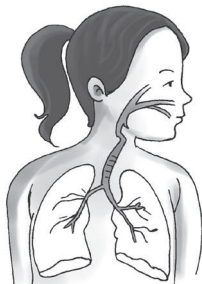

I



E

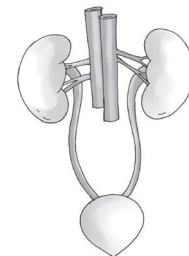

I

# 3. Me and My Family

## ANSWERS

### WARM UP

Enjoy singing this poem.

### TEST YOURSELF

#### A. Tick (✓) the correct answers.

1. Parents and their children living together in a home make a

(a) groups

(b) family

2. A diagram which shows the relationship among the members of a family is called a

(a) family tree

(b) fun tree

#### B. Fill in the blanks with the right word from the box.

right shelter help

1. Members in a family help one another.

2. We should respect our elders.

3. The family provides food, shelter, comfort and makes people safe.

#### C. Answer these questions.

1. Why is a family important?

**Ans.** A family provides food, shelter, comfort and makes people feel safe.

2. What is a joint family?

**Ans.** When parents and their children along with grandparents and aunts and uncles live together, it is called a joint family.

3. What is a family tree?

**Ans.** A family tree is a diagram which shows the relationship among the members of a family.

### CREATIVE CORNER

Write the names of your family members in the family tree.

**Ans.** Do it yourself.

### LIFE SKILLS

Your father has forgotten to buy a toy for you that he had promised to buy today. Now, he asks you to bring a glass of water for him. What will you do?

1. Give him water.

2. Say 'no' because you are angry with him.

# 4. Festivals and Recreation

## ANSWERS

### WARM UP

Students of Class 2 of a school have decided to give gifts to poor street children during a festival. Colour the petals that have things they should offer as gifts.

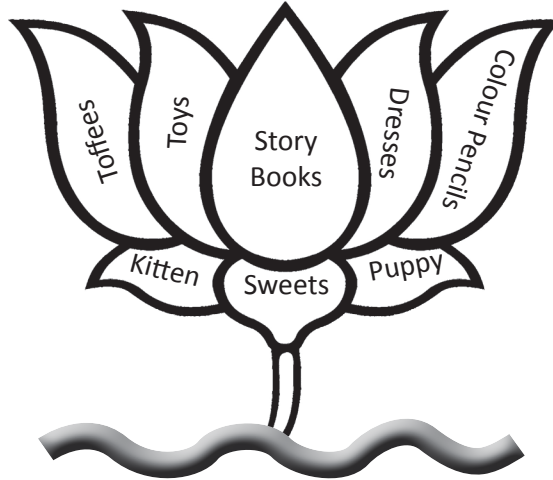

Ans. Do it yourself.

### TEST YOURSELF

#### A. Tick (✓) the correct answers.

1. Hockey is a/an

(a) outdoor game

(b) indoor game

2. Chess is a/an

(a) indoor game

(b) outdoor game

3. Festivals are a time of

(a) sadness

(b) joy

#### B. Fill in the blanks with the right word from the box.

relatives indoor special games outdoor

1. We can play games to refresh ourselves.

2. Cricket and football are outdoor games.

3. On festivals, we wear special clothes, eat special dishes and visit our relatives.

4. Chess and ludo are indoor games.

#### C. Answer these questions.

1. Why is recreation important?

Ans. Recreation is important because it is needed to refresh us.

2. Name two indoor games.

**Ans.** Chess and ludo.

---

3. Name two outdoor games.

**Ans.** Cricket and hockey.

---

4. Name two festivals.

**Ans.** Diwali and holi.

---

## **CREATIVE CORNER**

### **ACTIVITY**

**Let us learn how to make a Santa Claus.**

**Ans.** Do it yourself.

Colour the happy hours you have with your family.

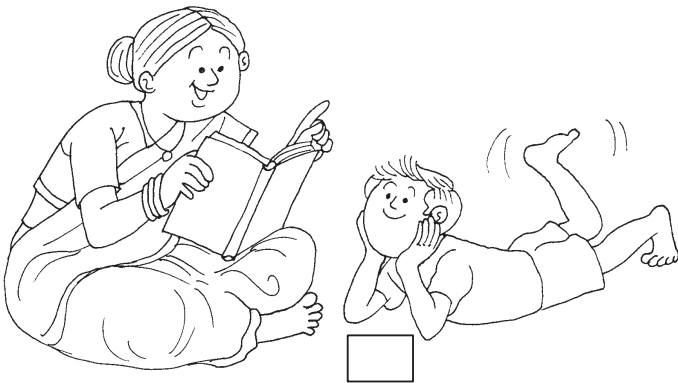
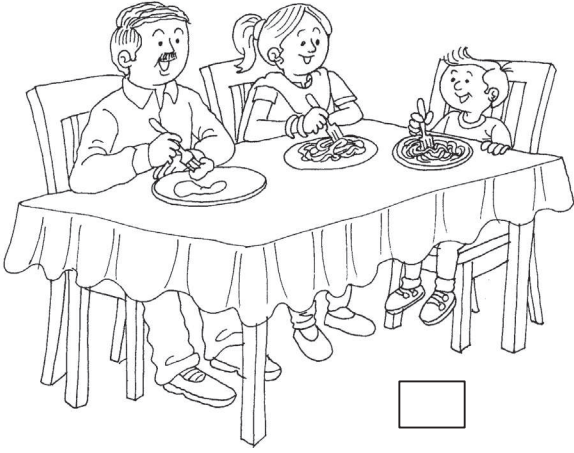

Ans. Do it yourself.



# 5. Our Food

## ANSWERS

### WARM UP

Lead Alka to the apple.

Ans. Do it yourself.

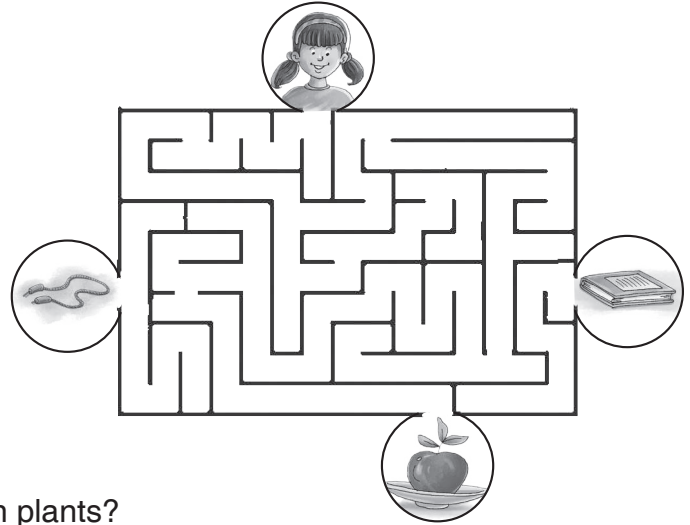

### TEST YOURSELF

#### A. Tick (✓) the correct answers.

1. Which of these things do we get from plants?

(a) honey

(b) wheat

2. Which of these things do we get from animals?

(a) fruits

(b) milk

3. Sugar is a/an

(a) energy-giving food

(b) body-building food

4. Which of these is a junk food?

(a) pizza

(b) apple

5. The meal we eat in the morning is called

(a) dinner

(b) breakfast

#### B. Name the following.

1. I am the king of fruits.

Mango

2. I am white in colour. You drink me every day.

Milk

3. I am red in colour. You eat me in salad.

Tomato

4. I am sweet in taste. Honeybees make me.

Honey

#### C. Answer these questions.

1. Why do we need food?

Ans. We need food because it helps us to live. Food also keeps us healthy and fit.

2. Where do we get our food from?

Ans. We get our food from plants and animals.

3. Name three main food groups.

Ans. Energy-giving foods, body-building foods and protective foods.

4. Write down any two good food habits.

Ans. (a) Wash your hands both before and after every meal.

(b) Chew your food well.

5. Is butter an energy-giving food?

Ans. Yes, butter is an energy-giving food.

## CREATIVE CORNER

### ACTIVITY

Draw the hands on the clocks to show the time you have

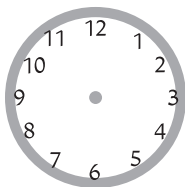

Breakfast

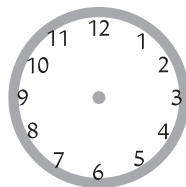

Lunch

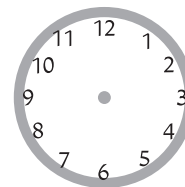

Dinner

Ans. Do it yourself.

### LIFE SKILLS

Tick (✓) what you should do while eating food.

1. Make a noise while eating.

2. Lick your fingers.

3. Be silent while eating.

4. Chew with your mouth closed.

The teacher should tell and explain life skills and tell how they should be inculcated in students.

Write 'A' below the things we get from animals and 'P' below the things we get from plants.



A



P



A



P



A

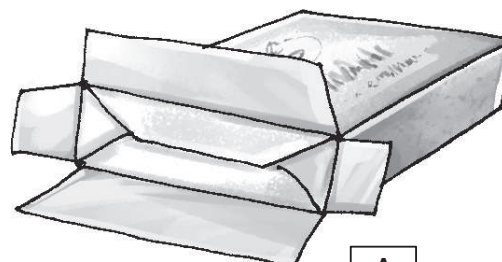

A

# 6. Water for All

## ANSWERS

### WARM UP

You have some excess water in your bottle. Where should you pour it out?



### TEST YOURSELF

A. Tick (✓) the correct answers.

1. All water comes from

(a) rain

(b) handpump

2. Rainwater collects in

(a) ponds

(b) taps

3. Water from this source is not clean.

(a) tubewell

(b) river

B. Answer these questions.

1. Why do living things need water?

Ans. All living things need water in order to live.

2. How do we get underground water?

Ans. Rainwater goes into the soil. This water collects under the ground. We dig wells and tubewells to get this underground water.

3. How does water become dirty?

Ans. Water becomes dirty due to the following activities:

● throwing garbage into water bodies

● washing clothes near water bodies

● bathing animals in water bodies.

### CREATIVE CORNER

#### ACTIVITY

Write a slogan on how to save water.

Ans. Do it yourself.

#### LIFE SKILLS

Write yes or no.

1. Do you keep the tap open while brushing teeth?

No

2. Do you flush the pot unnecessarily?

No

3. Do you make water dirty by throwing waste into it?

No

The teacher should tell and explain life skills and tell how they should be inculcated in students.

# 7. More About Water

## ANSWERS

### WARM UP

What is the right way of taking out water from the pot?

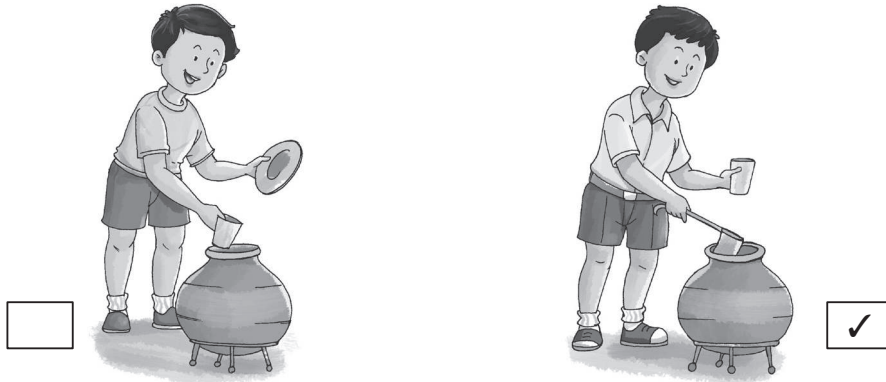

### TEST YOURSELF

#### A. Tick (✓) the correct answers.

1. What type of water is good for health?

(a) impure

(b) pure

2. Which disease is caused by polluted water?

(a) cholera

(b) malaria

3. We should \_\_\_\_\_ water.

(a) waste

(b) save

#### B. Fill in the blanks with the right word from the box.

open    boil or filter it    waste    prevent

1. To make water pure, we should boil or filter it.

2. It is our duty as citizens to prevent water pollution as it is harmful to plants, animals and human beings.

3. While brushing your teeth do not leave the tap open.

4. Never waste water.

#### C. Answer these questions.

1. What diseases are caused by impure water?

**Ans.** Cholera, typhoid and diarrhoea.

2. How does water get polluted?

**Ans.** Water gets pollution by garbage and harmful substances thrown into the rivers.

Other activities like washing clothes, bathing, etc., also pollute water.

3. List three ways by which we can save water?

**Ans.** Three ways to save water are:

a. Close the tap well after use. b. Get fixed any leaking taps.

c. Use a bucket and mug to take a bath.

## **CREATIVE CORNER**

### **ACTIVITY**

**Ans.** Do it yourself.

Lead the bird to the water bowl.

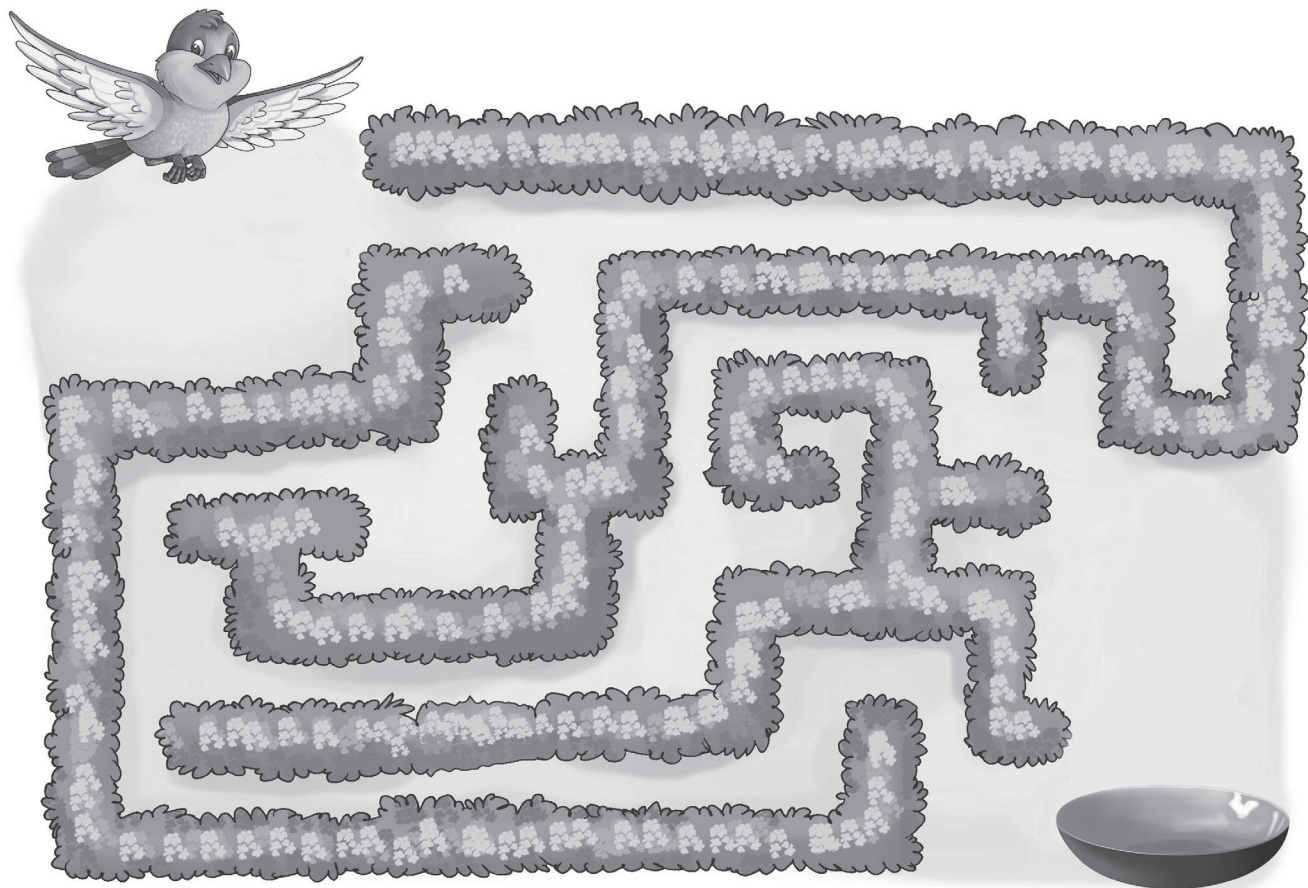

Ans. Do it yourself.

# 8. The House We Live In

## ANSWERS

### WARM UP

Write your address in the box given below.

**Ans.** Do it yourself.

Address:

### TEST YOURSELF

**A. Fill in the blanks. Choose the right words from the brackets.**

1.     *Kutch*     houses are mostly found in villages. [*Kutch/Pucca*]
2. Nomads live in     *caravans*    . [*flats/caravans*]
3. A/An     *igloo*     is a house made of snow and ice. [*igloo/caravan*]
4. A good house should be     *clean*    . [*dirty/clean*]

**B. Write 'T' for the true and 'F' for the false statements.**

- |   |                         |
|---|-------------------------|
| 1. Long long ago, people lived in caves.                          | <u>    <i>T</i>    </u> |
| 2. <i>Kutch</i> houses are stronger than the <i>pucca</i> houses. | <u>    <i>F</i>    </u> |
| 3. A tent is made from a thin cloth.                              | <u>    <i>F</i>    </u> |
| 4. Eskimos live in igloos.  | <u>    <i>T</i>    </u> |
| 5. A houseboat is a floating house.                               | <u>    <i>T</i>    </u> |

**C. Answer these questions.**

1. What does our house protect us from?

**Ans.** Our house protects us from heat, rain, cold and wild animals.

2. Name the materials used for making a *pucca* house.

**Ans.** Bricks, cement, iron and steel are used for making a *pucca* house.

3. What is a permanent house?

**Ans.** The house in which people live permanently is called a permanent house.

4. Where are houseboats found in India?

**Ans.** Houseboats are found in Kashmir.

5. In which areas do houses have sloping roofs?

**Ans.** Sloping roofs are found in areas where there is too much rainfall or snowfall.



**D. Match the following.**

1. Igloo

2. Tent

3. Caravan

4. Houseboat

a.



b.



c.



d.



## CREATIVE CORNER

### ACTIVITY

**Colour the houseboat.**

**Ans.** Do it yourself.

### LIFE SKILLS

**A glass of water fell accidentally on the staircase, making it very slippery. This staircase is also used by other people living in the same flat. What should you do?**

(a) Put up notice warning people not to use it.

(b) Wipe the staircase to make it dry.

The teacher should tell and explain life skills and tell how they should be inculcated in students.

# 9. Care of My Home

## ANSWERS

### WARM UP

Tick (✓) the room you would like to live in.

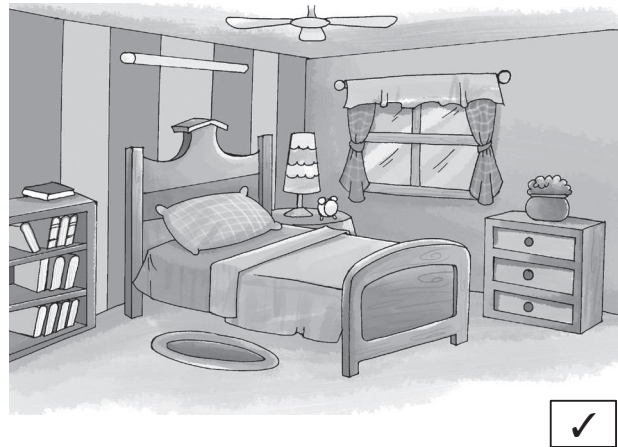

### TEST YOURSELF

A. Tick (✓) the correct answers.

1. A clean house is a/an

(a) unhealthy house

(b) healthy house

2. A thing that is used to clean our house is

(a) mop

(b) computer

B. Fill in the blanks with the right word from the box.

proper doors windows dustbin

1. We should throw garbage into the dustbin.

2. We should keep things at their proper places.

3. A good house should have enough doors and windows to let fresh air and sunlight in.

C. Answer these questions.

1. List three steps to keep our house clean.

Ans. a. We should dust everything in the house.

b. Empty the dustbin everyday.

c. Wash the bathrooms regularly.

2. What is a good house?

Ans. A house with enough number of doors and windows to let fresh air and sunlight in is called a good house.

# CREATIVE CORNER

## ACTIVITY

Look at the pictures of this drawing rooms. Write two differences.

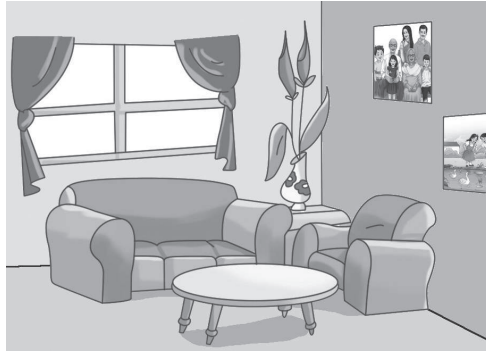

1. \_\_\_\_\_  
\_\_\_\_\_

2. \_\_\_\_\_  
\_\_\_\_\_  
\_\_\_\_\_

**Ans.** Do it yourself.

## LIFE SKILLS

**Ans.** Do it yourself.

**A. Tick (✓) the correct answers.**

1. Houses on wheels are called

(a) tents (b) caravans 

2. Kutcha houses are made of

(a) bricks and iron (b) mud and straw 

3. Houses in the hilly areas have

(a) sloping roofs (b) flat roofs 

4. A tent is made from

(a) silk (b) canvas **B. In the word grid, put an oval around the names of five things used to build houses.**

B	D	B	V	C	K	D	I
R	Q	H	W	B	N	F	R
I	V	W	O	O	D	G	O
C	P	K	P	N	O	H	N
K	X	R	S	M	H	M	K
Z	W	S	R	T	F	U	Z
C	E	M	E	N	T	D	B

# 10. The Clothes We Wear

## ANSWERS

### WARM UP

Write the size of your

1. shoes  2. shirt  3. jeans

Ans. Do it yourself.

### TEST YOURSELF

A. Tick (✓) the correct answers.

- |                                |                                     |              |                                     |
|--------------------------------|-------------------------------------|--------------|-------------------------------------|
| 1. We wear cotton clothes in   |                                     |              |                                     |
| (a) summer                     | <input checked="" type="checkbox"/> | (b) winter   | <input type="checkbox"/>            |
| 2. We wear woollen clothes in  |                                     |              |                                     |
| (a) summer                     | <input type="checkbox"/>            | (b) winter   | <input checked="" type="checkbox"/> |
| 3. We get silk from            |                                     |              |                                     |
| (a) earthworm                  | <input type="checkbox"/>            | (b) silkworm | <input checked="" type="checkbox"/> |
| 4. On a rainy day, we use a/an |                                     |              |                                     |
| (a) umbrella                   | <input checked="" type="checkbox"/> | (b) stick    | <input type="checkbox"/>            |

B. Write 'T' for the true and 'F' for the false statements.

- |                                     |                          |
|-------------------------------------|--------------------------|
| 1. Clothes are of different kinds.  | <input type="checkbox"/> |
| 2. Cotton clothes are warm.         | <input type="checkbox"/> |
| 3. We get wool from sheep.          | <input type="checkbox"/> |
| 4. We use gumboots in rainy season. | <input type="checkbox"/> |
| 5. Some people wear uniforms.       | <input type="checkbox"/> |

C. Fill in the blanks. Choose the right words from the box.

wool cotton season

- We wear clothes according to the season.
- In summer, we wear cotton clothes.
- Woollen clothes are made of wool.

D. Answer these questions.

- Why do we wear cotton clothes in summer?

Ans. Cotton clothes are light and they keep us cool. So, we wear cotton clothes in summer.

- Why do we wear woollen clothes in winter?

Ans. Woollen clothes keep us warm. So, we wear woollen clothes in winter.

3. Name two natural fibres.

Ans. Cotton and wool.

4. What is the colour of your favourite dress?

Ans. Do it yourself.

E. Match the following.

1. Astronaut

2. Nurse

3. Soldier

a.



b.



c.



## CREATIVE CORNER

### ACTIVITY

A. Paste your photograph on your school uniform.

Ans. Do it yourself.

B. Take a lady's finger and cut it into half. Dip it into poster colours and give impressions on the girl's dress as shown.

Ans. Do it yourself.

### LIFE SKILLS

On a hot summer day, you have returned from school sweating. What should you do with your uniform? (Tick (✓)).

1. Keep it in the cupboard.
2. Hang it in the air.
3. Dip it in water with detergent.

Match the people with their uniforms.

1.



a. Astronaut

2.



b. Doctor

3.



c. Soldier

4.

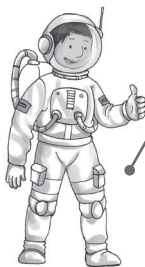

d. Lawyer

5.



e. Policeman

# 11. Air, Air Everywhere

## ANSWERS

### WARM UP

Sia has returned from school. It is too hot outside. What does she need? Tick (✓) the correct pictures.

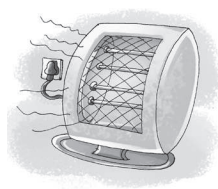

### TEST YOURSELF

#### A. Tick (✓) the correct answers.

1. Do plants need air?

(a) yes

(b) no

2. \_\_\_\_\_ is required for burning.

(a) water

(b) air

#### B. Answer these questions.

1. What is wind?

**Ans.** Moving air is called the wind.

2. Can plants live without air?

**Ans.** No, plants cannot live without air.

3. Why does a balloon become larger when it is blown?

**Ans.** A balloon becomes larger when it is blown because the air fills the space inside the balloon.

4. How can we prevent cough and cold?

**Ans.** We can prevent cough and cold by taking clean and fresh air.



## CREATIVE CORNER

### ACTIVITY

Lead Mini to the place where the air is clean.

**Ans.** Do it yourself.

### LIFE SKILLS

Write yes or no.

1. Do you burn fire-crackers?
2. Do you burn bits of paper?
3. Do you throw waste into the dustbin?

**Ans.** Do it yourself.

The teacher should tell and explain life skills and tell how they should be inculcated in students.

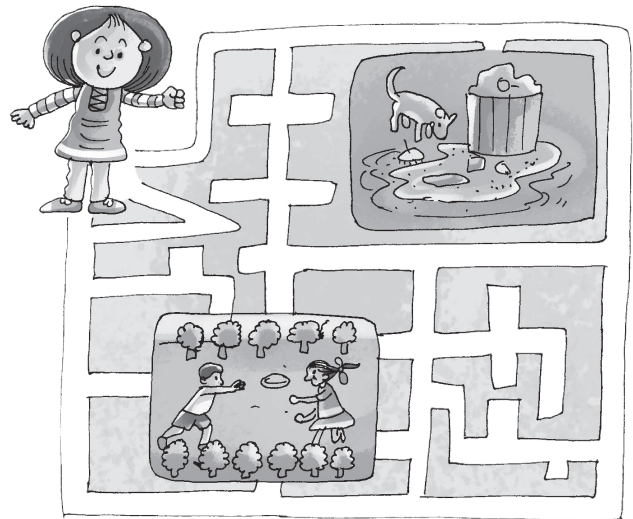

A. Put a cross (✓) below the pictures which show air pollution.











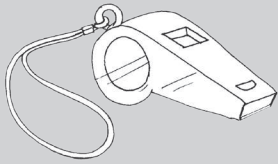
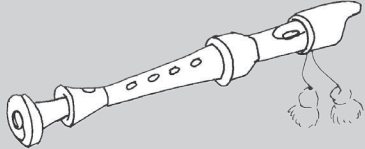
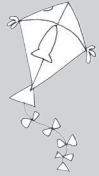

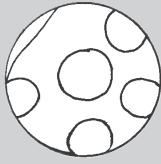
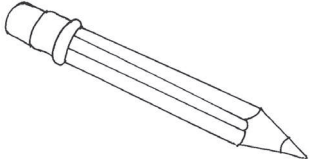
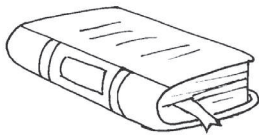
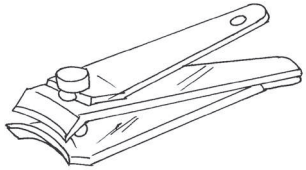
B. Colour the objects that need air to work.

# 12. Healthy Habits

## ANSWERS

### WARM UP

Circle the things you use to keep yourself clean.



### TEST YOURSELF

#### A. Tick (✓) the correct answers.

- We should trim our nails with a  
(a) knife  (b) nailcutter
- Our clothes should be clean and  
(a) ironed  (b) wet
- We should take our meals at  
(a) night only  (b) proper time

#### B. Write 'T' for the true and 'F' for the false statements.

- Exercise keeps us active.     T
- We should go to bed late at night.     F
- We should take a bath daily.     T
- Rest refreshes our body and brain.     T
- We should not talk while eating.     T

#### C. Fill in the blanks. Choose the right words from the box.

early    proper    morning    good

- We must have   good   habits to stay healthy.
- Get up   early   in the morning.
- Brush your teeth in the   morning   and at night.
- We should take   proper   rest.

#### D. Tick (✓) the things you do.

- Do you brush your teeth in the morning and at night?
- Do you take a bath every day?
- Do you watch TV while eating?
- Do you wash hands before and after each meal?

5. Do you comb your hair at least two times a day?

**Ans.** Do it yourself.

**E. Answer these questions.**

1. How much water should we drink every day?

**Ans.** We should drink 6 to 8 glasses of water every day.

2. Why should we take proper rest?

**Ans.** Rest refreshes our body and brain. So, we should take proper rest.

3. What is a bad touch?

**Ans.** A touch which you do not like is called a bad touch.

## CREATIVE CORNER

### ACTIVITY

**Make a chart on 'Ten Commandments of Health'. It should contain a list of dos and don'ts for keeping oneself healthy.**

**Ans.** Do it yourself.

### LIFE SKILLS



**Ans.** Observe and follow yourself.

# 13. Safety Rules

## ANSWERS

### WARM UP

Match the road signs with what they stand for.

1.  a. No horn
2.  b. Speed breaker
3.  c. No parking

### TEST YOURSELF

#### A. Tick (✓) the correct answers.

1. We should cross the road at the  
(a) giraffe crossing  (b) zebra crossing
2. Should we play on the road?  
(a) no  (b) yes
3. The red light means to  
(a) go  (b) stop

#### B. Write 'T' for the true and 'F' for the false statements.

1. Safety rules help to avoid accidents.           T
2. We should walk on the road.           F
3. We must not get in or get out from a moving bus.           T
4. We should go alone for a swim.           F
5. We should not run up or down the stairs.           T

#### C. Answer these questions.

1. Why should we follow safety rules?

Ans. We should follow safety rules to avoid accidents.

2. What should we use while learning to swim?

Ans. We should use a swimming tube while learning to swim.

3. Where should we play games?

Ans. We should play games in the park or in the playground.

## **CREATIVE CORNER**

### **ACTIVITY**

**Colour the traffic lights and name them.**

**Ans.** Do it yourself.

**A. Tick (✓) the good habits and cross (X) the bad habits.**

1. Watch television while eating.
2. Chew your food well.
3. Comb your hair regularly.
4. Eat uncovered food.
5. Go to bed early at night.
6. Wear dirty clothes.
7. Take a bath every day.
8. Do exercise every day.
9. Don't trim your nails.

**B. Which of the following children follow safety rules? Tick (✓) those who do and cross (X) those who do not.**

1. Mohit runs on the staircase.
2. Sohan plays on the road.
3. Adi gets off a moving bus.
4. Mita stays away from blades and knives.
5. Tia puts her hand out of the window of a moving bus.

**C. What do these symbols mean? Write with the help of the clues from the box.**

Stop



School Ahead



No Horn



No Entry

- ▶ No Parking
- ▶ Stop
- ▶ School Ahead
- ▶ No Horn
- ▶ No Entry



No Parking

**D. Colour the boxes of correct safety rules green.**

**Ans.** Do it yourself.

## TEST PAPER 1 (Based on Lessons 1 to 13)

### A. Tick (✓) the correct answers.

1. How many sense organs do we have?

a. four

b. five

2. We wear cotton clothes in

a. summer

b. winter

3. An igloo is made of

a. canvas

b. ice and snow

4. When do we have dinner?

a. at night

b. in the morning

5. We keep money in a

a. bank

b. hospital

### B. Fill in the blanks.

1. Wash you hands before and after each meal.

2. We smell with our nose.

3. A houseboat is a boat with rooms in it.

4. Eat your meals at proper time.

5. We wear woollen clothes in winter.

### C. Answer these questions.

1. Name two external organs.

**Ans.** Ears and nose.

2. Name three energy-giving foods.

**Ans.** Rice, potatoes and butter.

3. List three good food habits.

**Ans.** Three good food habits are: (1) Eat fresh and clean food.

(2) Chew your foods well, and (3) Drink plenty of water.

4. What is a nuclear family?

**Ans.** A family in which only the parents and their children live together is called

nuclear family.



# 14. My Neighbourhood

## ANSWERS

### WARM UP

Can you name this vehicle?

Ans. Ambulance



### TEST YOURSELF

#### A. Tick (✓) the correct answers.

1. To call the police, we dial

(a) 100

(b) 101

(c) 102

2. To call the fire brigade, we dial

(a) 100

(b) 101

(c) 102

3. The full form of ATM is

(a) Automated Teller Machine

(b) Automated Time Machine

(c) Automated Teller Motor

#### B. Fill in the blanks with the right word from the box.

letter school ambulance police money

1. Police helps to maintain peace.

2. We dial 102 to call an ambulance.

3. We keep our money in a bank.

4. We post letter in a letter box.

5. We go to school to learn many things.

#### C. Answer these questions.

1. Where will you go to buy fruits and toys?

Ans. We will go to market to buy fruits and toys.

2. Where do we keep our money?

Ans. We keep our money in a bank.

3. Whom do we call if there is a fire?

Ans. We call the fire brigade if there is a fire.

4. Where will you post a letter?

Ans. We will post a letter in a letterbox.

## CREATIVE CORNER

### ACTIVITY

Colour the fire engine.

Ans. Do it yourself.

### LIFE SKILLS

Ans. Do it yourself.

# 15. Our Helpers

## ANSWERS

### WARM UP

Match the persons with their tools.

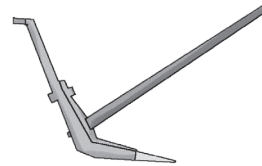

**Ans.** Carpenter – saw; farmer – plough; electrician – screwdriver

### TEST YOURSELF

**A. Tick (✓) the correct answers.**

1. Who stitches our clothes?

(a) carpenter

(b) tailor

2. Who fits and repairs our taps and pipes?

(a) barber

(b) plumber

3. Who brings us letters?

(a) postman

(b) watchman

**B. Answer these questions.**

1. Who makes furniture?

**Ans.** Carpenter

2. Who repairs shoes?

**Ans.** Cobbler

## CREATIVE CORNER

### ACTIVITY

Match the people with their tools.

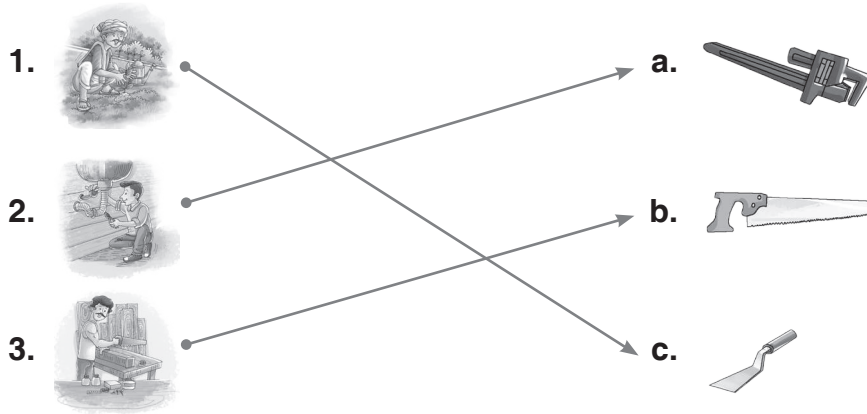

### LIFE SKILLS

Name the following.



Magician



Singer



Chef

The teacher should tell and explain life skills and tell how they should be inculcated in students.

# Worksheet

# 9

(Based on Theme 9: Places in the Neighbourhood)

A. The following people help us in many ways. Look at the pictures of the people and complete the words grid with their names.



<sup>1</sup>C A R P E N <sup>3</sup>T E R

O A



<sup>2</sup>P L U M B E R



I

B

L

<sup>5</sup>M

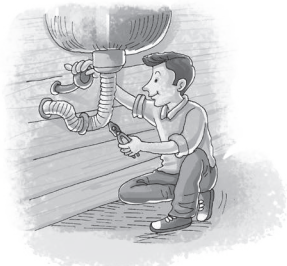

L

<sup>4</sup>P O S T M A N

E

R

S



R

O

N

B. Tick (✓) the services you have in your neighbourhood.

1. Post office

2. Hospital

3. Market

4. Fire station

5. Police station

6. Bank

7. Park

8. Greengrocer

9. ATM machine

10. School

Ans. Do it yourself.

# 16. Plants Around Us

## ANSWERS

### WARM UP

Name these parts of a plant.



FRUIT



SEED



LEAF



FLOWER

### TEST YOURSELF

A. Tick (✓) the correct answers.

1. Which of these is a tree?

(a) neem

(b) rose

2. Which of these is a herb?

(a) spinach

(b) cotton

B. Answer these questions.

1. What are shrubs?

**Ans.** Plants that are smaller in size than the trees are called shrubs. They have thin, hard and woody stems.

2. What are herbs?

**Ans.** Herbs are very small plants with green and soft stems.

3. Name the two parts of a plant.

**Ans.** Roots and stem.

### CREATIVE CORNER

#### ACTIVITY

Collect some leaves of different shapes and sizes. Stick them with glue to give shapes of different animals, like the one given here.

**Ans.** Do it yourself.

## LIFE SKILLS

**Write yes or no.**

1. Do you water plants? \_\_\_\_\_

2. Do you pluck flowers? \_\_\_\_\_

**Ans.** Do it yourself.

The teacher should tell and explain life skills and tell how they should be inculcated in students.

# 17. Plants are Useful

## ANSWERS

### WARM UP

Tick (✓) the things we get from plants.

1. Milk

2. Egg

3. Wood

4. Sugar

5. Wool

6. Rubber

### TEST YOURSELF

A. Tick (✓) the correct answers.

1. Wood of this tree is used for making cricket bats.

(a) willow tree

(b) rubber tree

2. We get this from jasmine and rose plants.

(a) medicine

(b) perfume

3. The fibres of this plant are used to make ropes and mats.

(a) jute plant

(b) mustard plant

4. We make furniture from

(a) rubber

(b) wood

5. Leaves of this plant are useful in cold and cough.

(a) tulsi

(b) mustard

B. Answer these questions.

1. What is jute used for?

Ans. Jute is used for making cloth, sacks, ropes and mats.

2. Name two spices.

Ans. Clove and cumin.

3. Where do we get rubber from?

Ans. We get rubber from the latex of a rubber tree.

4. What is latex?

Ans. Latex is a milky white liquid obtained from a rubber tree. It is used to make rubber.

5. Why should we grow more plants?

Ans. We should grow more plants because they make the air fresh and clean.

## CREATIVE CORNER

### ACTIVITY

A. Complete the names of the things that we get from plants.

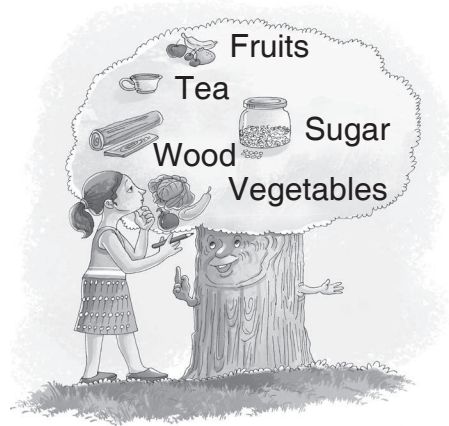

B. Watermelon

1. Tear red and green crepe papers into pieces.
2. Using your thumb and palm, roll these pieces of paper into small balls.
3. Draw glue and paste these balls on the watermelon you have drawn.

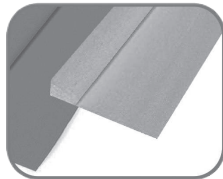

Step 1

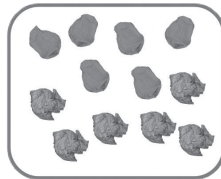

Step 2

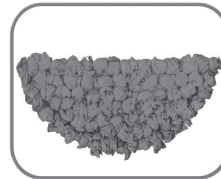

Step 3

**Ans.** Do it yourself.



A. Write 'T' below a tree, 'S' below a shrub, 'H' below a herb, 'C' below a climber and 'Cr' below a creeper.



T



C



H



T



H



Cr

B. Solve the following riddles with the help of the box.

creeper herb shrub climber tree

- I am very big and strong. My stem is called a trunk.  
I am a tree
- I have a hard and woody stem.  
I am a shrub
- I am a small plant. I have a green and soft stem.  
I am a herb
- I have a weak stem. I need support to stand straight.  
I am a climber
- I grow along the ground. I have a weak and thin stem.  
I am a creeper

# 18. Animals Around Us

## ANSWERS

### WARM UP

Tick (✓) the animals you have seen.

- |             |                          |           |                          |
|-------------|--------------------------|-----------|--------------------------|
| a. dog      | <input type="checkbox"/> | b. donkey | <input type="checkbox"/> |
| c. camel    | <input type="checkbox"/> | d. lion   | <input type="checkbox"/> |
| e. elephant | <input type="checkbox"/> | f. monkey | <input type="checkbox"/> |

**Ans.** Do it yourself.

### TEST YOURSELF

**A. Tick (✓) the correct answers.**

1. Which of these animals is a wild animal?

- (a) cow
- (b) lion

2. Fishes breathe with the help of

- (a) lungs
- (b) gills

3. Birds live in a

- (a) nest
- (b) kennel

**B. Fill in the blanks with the right word from the box.**

air    wild    pet

1. A dog is a pet animal.
2. An elephant is a wild animal.
3. Animals need air to breathe.

**C. Answer these questions.**

1. Name two land animals.

**Ans.** Dog and cat.

2. Name two animals which live in trees.

**Ans.** Squirrel and monkey.

3. List three characteristics of animals.

**Ans.** a. All animals have babies or eggs.

b. Animals need food.

c. Animals need air to breathe.

4. List four ways in which we can take care of animals.

**Ans.** 1. Do not force animals to work beyond their capacity.

2. Show affection and care for animals.

3. Give proper food, comfortable shelter and clean drinking water to animals.

4. We should make sure that hoofs of animals like horse are protected with a horseshoe.

## CREATIVE CORNER

### ACTIVITY

**A. Here are lines of some poems. Write the animal's name in the blanks.**

1. Baa, baa, black \_\_\_ sheep \_\_\_.

Have you any wool?

2. Hickory, Dickory Dock, the

\_\_\_ mouse \_\_\_ ran up the clock.

3. Higgledy Piggledy, my black \_\_\_ hen \_\_\_.

she lays eggs for gentlemen.

**B. Tear glazed papers of different colours into small pieces. Paste them on Goofy, the giraffe. Also, colour it using crayons.**

**Ans.** Do it yourself.

Write 'D' below the domestic animal, 'W' below the wild animal and 'P' below the pet animal.



W

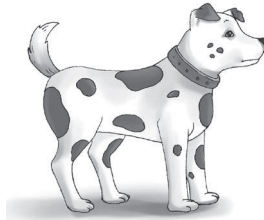

P

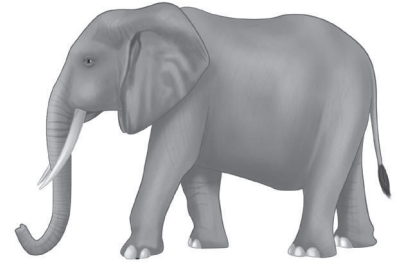

W

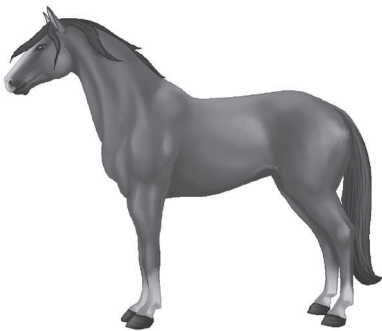

D

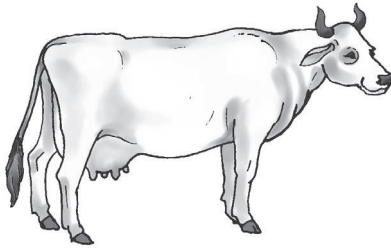

D

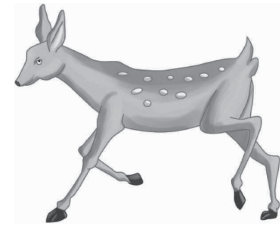

D

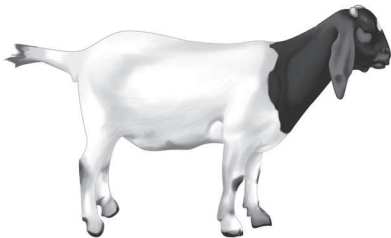

D

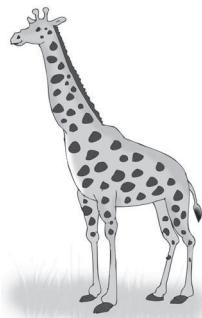

W

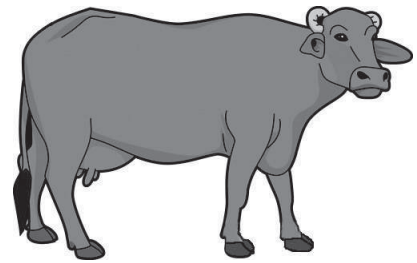

D

# 19. Means of Transport

## ANSWERS

### WARM UP

Match the vehicles with their wheels.

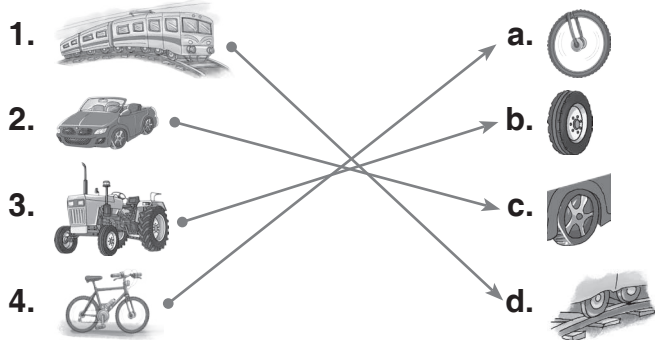

### TEST YOURSELF

A. Tick (✓) the correct answers.

1. Which of these is a means of land transport?

(a) Car

(b) Helicopter

2. Which of these is a means of water transport?

(a) Helicopter

(b) Boat

3. Which is the fastest means of transport?

(a) Train

(b) Aeroplane

B. Answer these questions.

1. Why do we need a means of transport?

Ans. We need a means of transport to travel from one place to another.

2. Which means of transport can be used to go to other countries?

Ans. Ship and aeroplane.

### CREATIVE CORNER

#### ACTIVITY

Colour the rocket.

Ans. Do it yourself.

## LIFE SKILLS

**You are returning from school on your bicycle. Unfortunately, one of its tyres gets punctured. What will you do?**

1. Still ride it.

2. Get down and walk with the bicycle to a repairing shop.

The teacher should tell and explain life skills and tell how they should be inculcated in students.

Find out the number of wheels each means of transport has. Write it in the box.

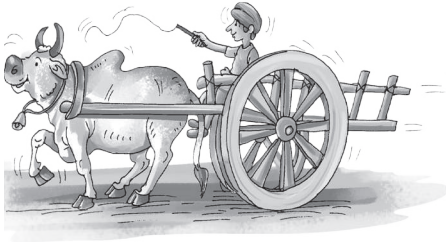

2



3

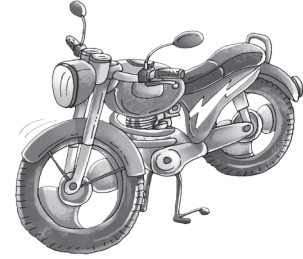

2



4

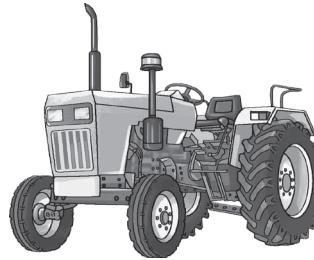

4



2

# 20. Communication

## ANSWERS

### WARM UP

Write the sequence 1, 2 or 3 from the oldest to the newest invention.



3

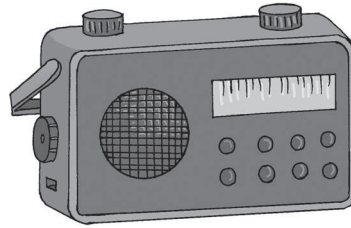

1



2

### TEST YOURSELF

#### A. Tick (✓) the correct answers.

1. Letters are a means of

(a) written communication

(b) oral communication

2. Modern ways of communication help us to

(a) connect with people

(b) disconnect with people

#### B. Fill in the blanks with the right word from the box.

games communication oral

1. Communication is the way in which one person exchanges feelings, needs and other information with another person.

2. Oral communication is when we talk to each other directly or through a phone.

3. We can play games on mobiles or computers.

#### C. Answer these questions.

1. Name the two main types of communication.

**Ans.** Verbal communication and non-verbal communication.

2. What is a non-verbal communication?

**Ans.** A non-verbal communication occurs when we express ourselves through gestures such as smile, waving hands or pointing fingers.

3. List three misuses of communication devices.

**Ans.** ● Our eyesight and posture are affected.

● A lot of time is wasted.

● People spend more time indoors which is not good for health.



## CREATIVE CORNER

### ACTIVITY

**Ans.** 1. Do it yourself.

**Ans.** 2. Do it yourself.

Which of the following symbols remind you about communication? Tick (✓) the symbols.



India Post



# 21. The Sun, Moon, Sky and Stars

## ANSWERS

### WARM UP

What makes you to see the world?

Yes, the bright sun. The sunshine makes all of us feel happy and energetic. Go out and make a list of all that you can see around in the morning.



**Ans.** Do it yourself.

### TEST YOURSELF

**A. Tick (✓) the correct answers.**

1. The sun appears small because it is

(a) far from the Earth  (b) small in size

2. The Moon is the neighbour of the Earth.

(a) nearest  (b) farthest

3. How many planets are there in the solar system?

(a) nine  (b) eight

**B. Write 'T' for the true and 'F' for the false statements.**

1. The moon has its own light.

F

2. The stars are very big in size.

T

3. During summers, the sun is very bright.

T

4. Spinning of the Earth causes day and night.

T

5. Sunlight is not necessary for life.

F

**C. Answer these questions.**

1. What do we get from the Sun?

**Ans.** We get light and heat from the Sun.

2. Name any three planets?

**Ans.** Mercury, Venus, Jupiter.

3. How does the sky look in the rainy season?

**Ans.** The sky looks dark due to clouds in the rainy season.

The Sun is hidden behind two clouds.

## CREATIVE CORNER

### ACTIVITY

Colour the picture.



**Ans.** Do it yourself.

Tick (✓) the activities that are good for the Earth and cross (X) the activities that are not good for the Earth.



# 22. Time

## ANSWERS

### WARM UP

Can you name this object?



Ans. Sand clock

### TEST YOURSELF

A. Tick (✓) the correct answers.

1. The sun rises in the

(a) evening

(b) morning

2. How many days are there in a week?

(a) 8

(b) 7

3. A year has

(a) 10 months

b. 12 months

B. Write the missing names of the months.

January

**February**

March

**April**

May

**June**

July

**August**

**September**

October

**November**

December

C. Read the time on the clocks.



Ans. 8:25

3.00

10:10

### CREATIVE CORNER

#### ACTIVITY

Learn the poem.

Ans. Do it yourself.

#### LIFE SKILLS

Fill in the blanks.

Ans. Early to bed and early to rise makes a man healthy, wealthy and wise.

# 23. Space and Direction

## ANSWERS

### WARM UP

Can you tell the full form of NEWS?

North                      East  
West                      South

### TEST YOURSELF

**A. Tick (✓) the correct answers.**

1. The sun rises in the

(a) west

(b) east

2. The number of main directions is

(a) two

(b) four

**B. Name the four directions.**

East                      North  
West                      South

### CREATIVE CORNER

#### ACTIVITY

**Ans.** Do it yourself.

Match the following.

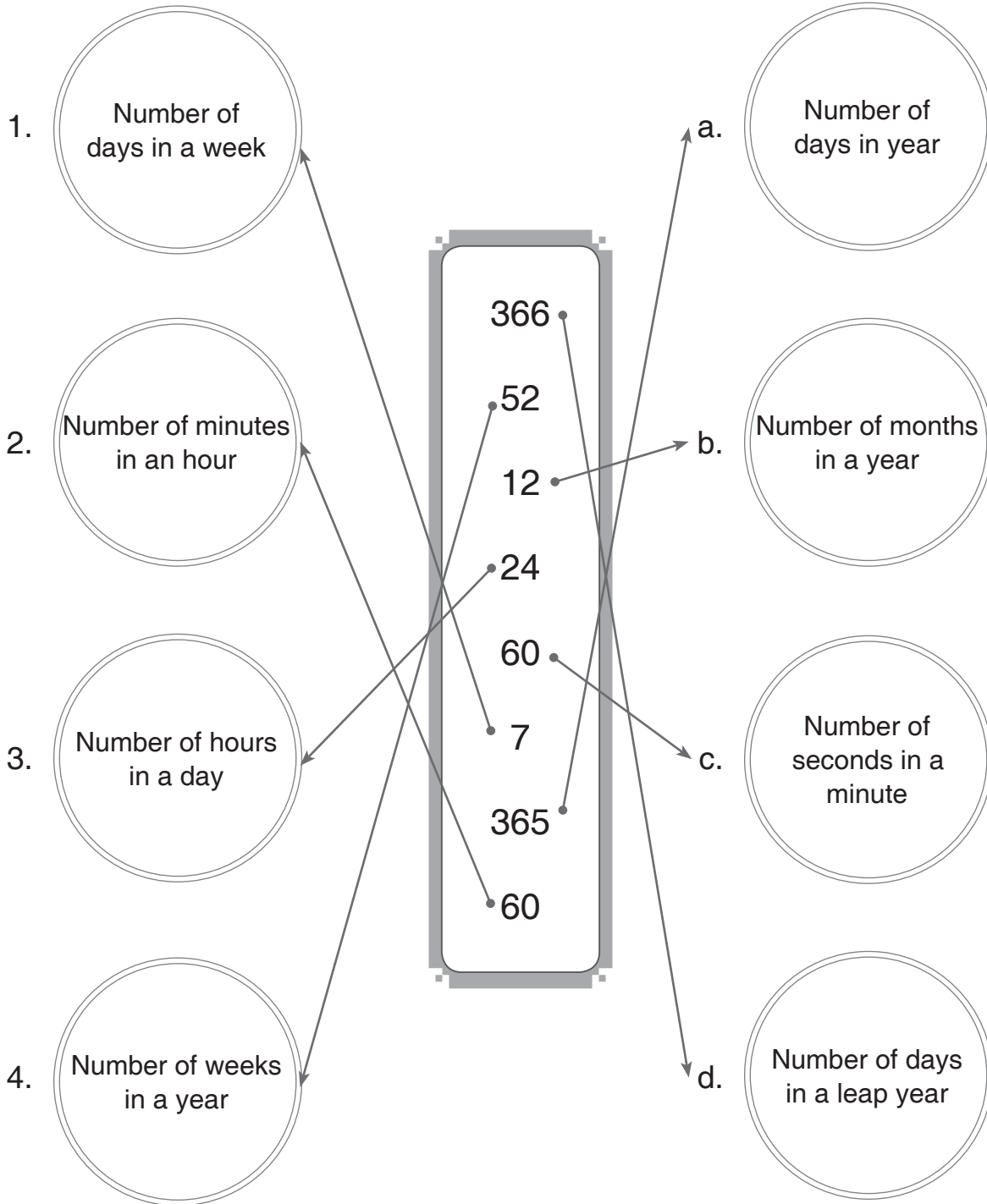



## TEST PAPER 2 (Based on Lessons 13 to 23)

### A. Tick (✓) the correct answers.

- |                                  |                                     |                    |                                     |
|----------------------------------|-------------------------------------|--------------------|-------------------------------------|
| 1. A lion is a                   |                                     |                    |                                     |
| a. wild animal                   | <input checked="" type="checkbox"/> | b. domestic animal | <input type="checkbox"/>            |
| 2. To call on ambulance, we dial |                                     |                    |                                     |
| a. 101                           | <input type="checkbox"/>            | b. 102             | <input checked="" type="checkbox"/> |
| 3. To call police, we dial       |                                     |                    |                                     |
| a. 100                           | <input checked="" type="checkbox"/> | b. 101             | <input type="checkbox"/>            |
| 4. Insects breathe through       |                                     |                    |                                     |
| a. gills                         | <input type="checkbox"/>            | b. air holes       | <input checked="" type="checkbox"/> |
| 5. The Sun rises in the          |                                     |                    |                                     |
| a. west                          | <input type="checkbox"/>            | b. east            | <input checked="" type="checkbox"/> |

### B. Fill in the blanks.

1. Rubber is made from the latex of a rubber tree.
2. The carpenter makes furniture.
3. The woody stem of a tree is called a trunk.
4. Aeroplane is the fastest means of transport.
5. There are seven days in a week.

### C. Answer these questions.

1. List three characteristics of animals

**Ans.** a. Animals grow b. Animals need food c. Animals reproduce.

2. What is a creeper?

**Ans.** A creeper is a plant which grows along the ground is called a creeper.

3. Name two water animals?

**Ans.** Fish and octopus are water animals.

4. Name the four directions.

**Ans.** East, West, North, South.

5. Name the three main seasons of India.

**Ans.** Rainy season, winter season and summer season.