

Means of Transport



6

LESSON PLAN

SPECIFIC OBJECTIVES

The students will learn about

- what transport is
- the necessity of transport system
- land transport
- water transport
- air transport

TEACHING AIDS

A labelled chart paper containing pictures of different means of transport, flashcards, a projector, blackboard, chalk, duster, pointer, etc.

TEACHING STRATEGY

- The teacher will start with 'Warm Up'. He/She will ask the students to do the activity.
- The teacher should give the students an introduction on transport system and its necessity for us.
- He/She, then, will tell about the different means of transport.
- The teacher, then, will tell about, land transport in detail.
- After this, the teacher will tell about water transport and air transport in detail.

BOOST UP

- The teacher may tell a little about the history of transport system—only some important facts like invention of the steam engine.
- The teacher may show pictures of old and modern cars to inculcate a sense of gradual change (modernisation) of transport system.
- The teacher may show pictures of different trains running in different countries.
- The teacher may show pictures of ports, airports, railway stations, motor vehicle manufacturing units, aeroplane manufacturing units, etc.
- The teacher may tell about eco-friendly vehicles like battery-operated bikes, etc.

- The teacher then will ask the students to solve the exercises to evaluate the learning of the students.
- The teacher should give a brief introduction on the topic given in life skills.

EXPECTED LEARNING OUTCOMES







The students are able to learn about

- transport system
- land transport
- water transport
- air transport
- eco-friendly transport

EVALUATIVE QUESTIONS

The teacher may ask the following questions to evaluate his/her students.

1. What do you mean by transport?
2. What are the different types of transport?
3. Name two means of transport used in water.
4. Name three means of air transport.
5. Look at the pictures. The pictures are the parts of some means of transport. Write the name of the means of transport for each.

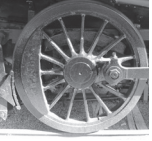
Pictures							
Name of means of transport